

INSTALLATION INSTRUCTIONS

FORM EZRAIL II 6-08

**WARNING:**

DEVIATION FROM THESE INSTRUCTIONS MAY LEAD TO IMPROPER ENGINE OPERATION WHICH COULD CAUSE PERSONAL INJURY TO OPERATORS OR OTHER NEARBY PERSONNEL.

1.0 DESCRIPTION

1.1 EZRail is a comprehensive line of modular ignition wiring and coil-mounting systems. **EZRail** systems are thoroughly tested to ensure maximum reliability and performance. Operational and functional benefits include:

- Extremely easy to install, just mount and connect components.
- Complete wiring and mounting system from the ignition unit to the ignition coils. Eliminates hours of wire and conduit cutting in the field. Guarantees against skinned insulation due to long conduit pulls.
- Universal design takes advantage of standard cables, wiring rails and integral/flange or off-mounted coils (shielded or unshielded). Optional bolt-on coil mounting rails.
- Flexible and upgradeable. If coil types are changed, e.g., from unshielded to shielded or integral, the same wiring rail can be used without modification. The same is true if the coil mounting rail is added later.
- Premium construction materials include high-quality aluminum extrusions, sealed junction boxes, military-style connectors and harnesses and stainless steel hardware. Connector back shells are potted and strain-relieved, and external surfaces are plated or anodized for corrosion resistance.
- Standard Altronic ignition components, including the primary and secondary cables and leads, are incorporated into the design, which allows for quick, cost-effective repair and service in the field. In the unlikely event that the rail itself requires service (or if on-engine mechanical work is required), the **EZRail** system can be easily disconnected, removed, and re-installed.



INSTALLATION INSTRUCTIONS

2.0 HIGH SPEED ENGINES (REFER TO DIAGRAM ON PAGE 3)

2.1 COMPONENTS

- A. **EZRail (Wiring) Assembly - 593qab-xyzm** - Anodized aluminum rail(s) are available in custom lengths to suit specific applications; refer to **Form EZRail AL**. Military-style connectors have potted backshells. Coil connectors are spaced to align with each engine cylinder.
- B. **Coil Mounting Assembly - 5805ab-xyz (Optional)** - Anodized aluminum coil mounting rail(s) may be mounted directly to the **EZRail** or separately at the user's option.
- C. **Junction Box - 593axx-xxx**, heavy-duty, corrosion resistant construction, military-style connectors, a shutdown lead connector, and an easily-accessible timing lead.
- D. **Harnesses** (all connectors sealed with epoxy potting)
Ignition to J-Box - 793101-L, one straight and one right-angle connector.
J-Box to Rail Assembly - 793101-L - one straight and one right-angle connector, or **793102-L**, two right-angle connectors (use only up to 8 circuits per bank).
Shutdown Lead - 593052-L, straight or **593057-L**, right-angle connector.

2.2 MOUNTING

- A. **J-Box** - Mount at either the no. 1 end or opposite end of the engine, based on the J-Box part number that was ordered. Avoid locations that might cause exposure to excessive vibration or heat.
- B. **EZRail Assembly** - Determine an appropriate mounting point. Avoid locations which might cause exposure to excessive vibration or heat.
- C. **Coil Mounting Assembly (Optional)** - Determine appropriate mounting point(s) and mount using included hardware. Coil rails may be mounted directly to the **EZRail Assembly**.

2.3 CONNECTIONS

- A. **J-Box to Ignition** - Connect harness **793101-L** to **CPU-95 Ignition**.
- B. **J-Box to Rail**
Connect harness **793101-L** or **793102-L** as appropriate.
- C. **Shutdown Lead** - Connect cable **593052-L** or **593057-L** to the shutdown lead connection.
NOTE: Pin A = Shutdown Lead, Pin B = N.C., Pin C = Ground.
- D. **Timing Lead** - A #1 cylinder primary wire loop is accessible under the timing lead connector cover. Use with inductive timing light on completely shielded systems. For timing light use on all cylinders use Altronic Safe-T-Lead™.

NOTE: Standard rail components are laid out for applications where lead "A" of the ignition system connects to the first cylinder in the engine firing order through the rail with the "A" suffix.

— If ignition lead "A" connects to the first cylinder in the engine firing order, the rail with suffix "A" mounts on that bank of the engine.

— If ignition lead "A" is connected to a cylinder other than the first cylinder in the engine firing order, contact the factory for further information. A different memory chip for the ignition system (CPU-95) or a non-standard junction box may be required.

NOTE: J-Box part number is specific to whether mounted at the no. 1 end or the opposite end of the engine - see form EZRail AL.

NOTE: Mount J-Box as close to the appropriate end of the engine as is practical using included or other suitable hardware.

NOTE: 19-pin connector end of rail (for both banks of a V-engine) must be installed at the end of the engine closest to the J-Box.

ALTRONIC EZRAIL MODULAR IGNITION RAIL SYSTEM

SYSTEM OVERVIEW FOR HIGH SPEED ENGINES

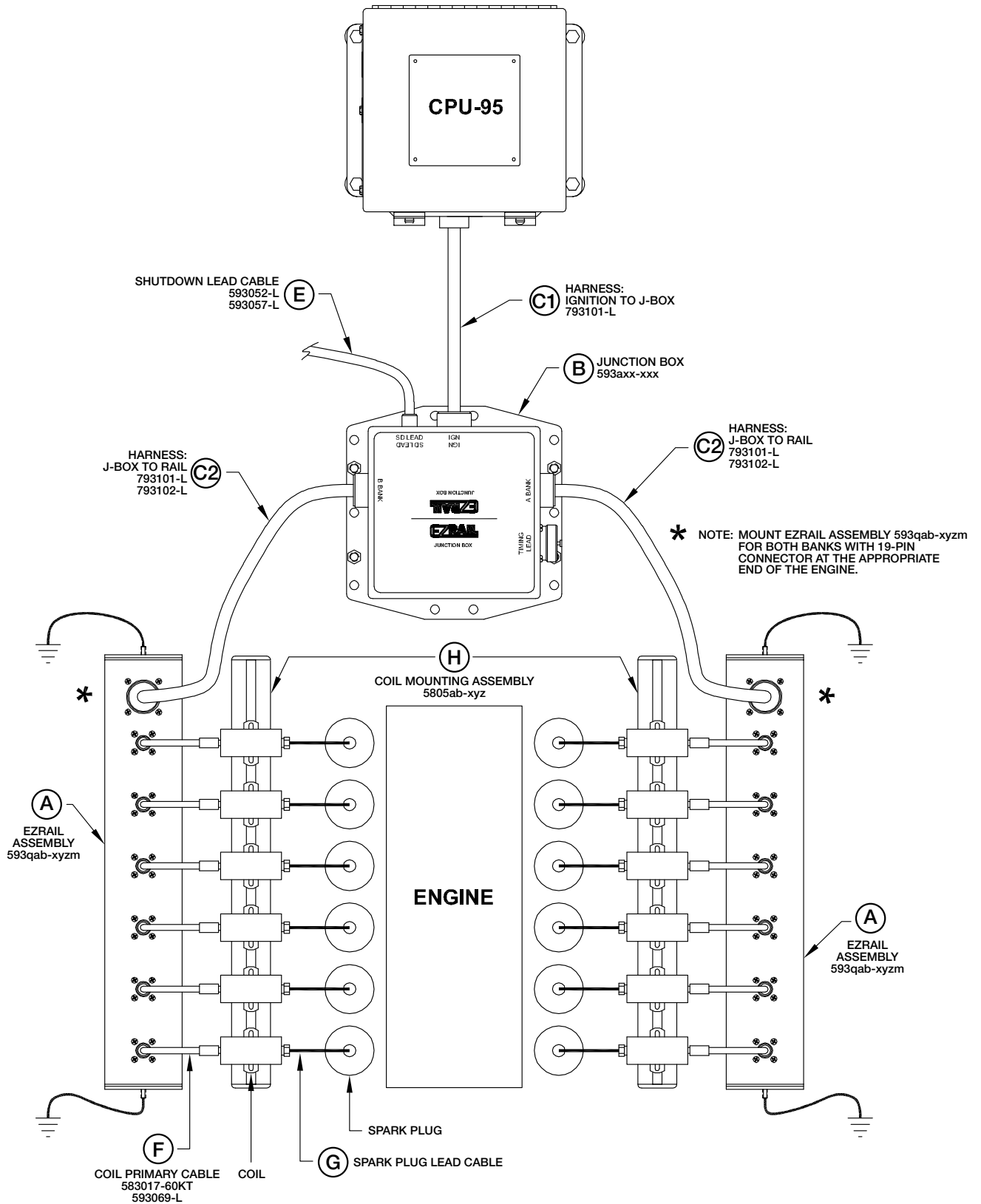

INSTALLATION INSTRUCTIONS

3.0 INTEGRAL ENGINES (REFER TO DIAGRAM ON PAGE 5)

3.1 COMPONENTS

- A. **EZRail (Wiring) Assembly – 593qab-xyzm** – Anodized aluminum rail(s) are available in custom lengths to suit specific applications; refer to **Form EZRail AL**. Military-style connectors have potted backshells. Coil connectors are spaced to align with each engine cylinder. Due to the length of the engine in some cases, two rails, with an inter-connecting harness, are required for each bank of cylinders.
- B. **Coil Mounting Assembly – 5805ab-xyz (Optional)** – Anodized aluminum coil mounting rail(s) may be mounted directly to the **EZRail** or separately at the user's option.
- C. **Junction Box – 593axx-xxx** – The junction box features heavy-duty, corrosion resistant construction, military-style connectors, a shut-down lead connector, and an easily-accessible timing lead.
- D. **Harnesses** (all connectors sealed with epoxy potting)
Ignition to J-Box – 793101-L, one straight and one right-angle connector.
J-Box to Rail Assembly – 793101-L, one straight and one right-angle connector or **793102-L**, two right-angle connectors (use only up to 10 circuits per bank).
Rail 1 to Rail 2 Assembly – 793102-L, two right-angle connectors.
Shutdown Lead – 593052-L, straight or **593057-L**, right-angle connector or **593069-L** (if the CPU-2000 Diagnostic Module is used).

NOTE: The 19-pin connector adjacent to the EZRail label is the input connector. The output connector is at the opposite end of the rail.

NOTE: J-Box part number is specific to whether mounted at the no. 1 end or the opposite end of the engine – see form EZRail AL.

NOTE: Mount J-Box as close to the appropriate end of the engine as is practical using included or other suitable hardware.

NOTE: 19-pin input connector end of rail (for both banks of a V-engine) must be installed at the end of the engine closest to the J-Box.

3.2 MOUNTING

- A. **J-Box** – Mount at either the no. 1 end or opposite end of the engine, based on the J-Box part number that was ordered. Avoid locations that might cause exposure to excessive vibration or heat.
- B. **EZRail Assembly** – Determine an appropriate mounting point. Avoid locations which might cause exposure to excessive vibration or heat.
- C. **Coil Mounting Assembly (Optional)** – Determine appropriate mounting point(s) and mount using included hardware. Coil rails may be mounted directly to the **EZRail Assembly**.

3.3 CONNECTIONS

- A. **J-Box to Ignition** — Connect harness **793101-L** to **CPU-2000 Ignition**.
- B. **J-Box to Rail**
Connect harness **793101-L** or **793102-L** as appropriate.
- C. **Rail to Rail** — Connect harness **793102-L** from **Rail 1** to **Rail 2**.
- D. **Shutdown Lead** — Connect cable **593052-L** or **593057-L** to the shut-down lead connection. If the CPU-2000 diagnostic module 291105-1 is used, connect cable **593069-L** between it and the J-Box.
- E. **Timing Lead** — A #1 cylinder primary wire loop is accessible under the timing lead connector cover. Use with inductive timing light on completely shielded systems. For timing light use on all cylinders use Altronic Safe-T-Lead™.

4.0 HAZARDOUS AREA CERTIFICATION

CSA CERTIFIED, Class I, Div. 2, Groups C & D

ALTRONIC EZRAIL MODULAR IGNITION RAIL SYSTEM

SYSTEM OVERVIEW FOR INTEGRAL ENGINES

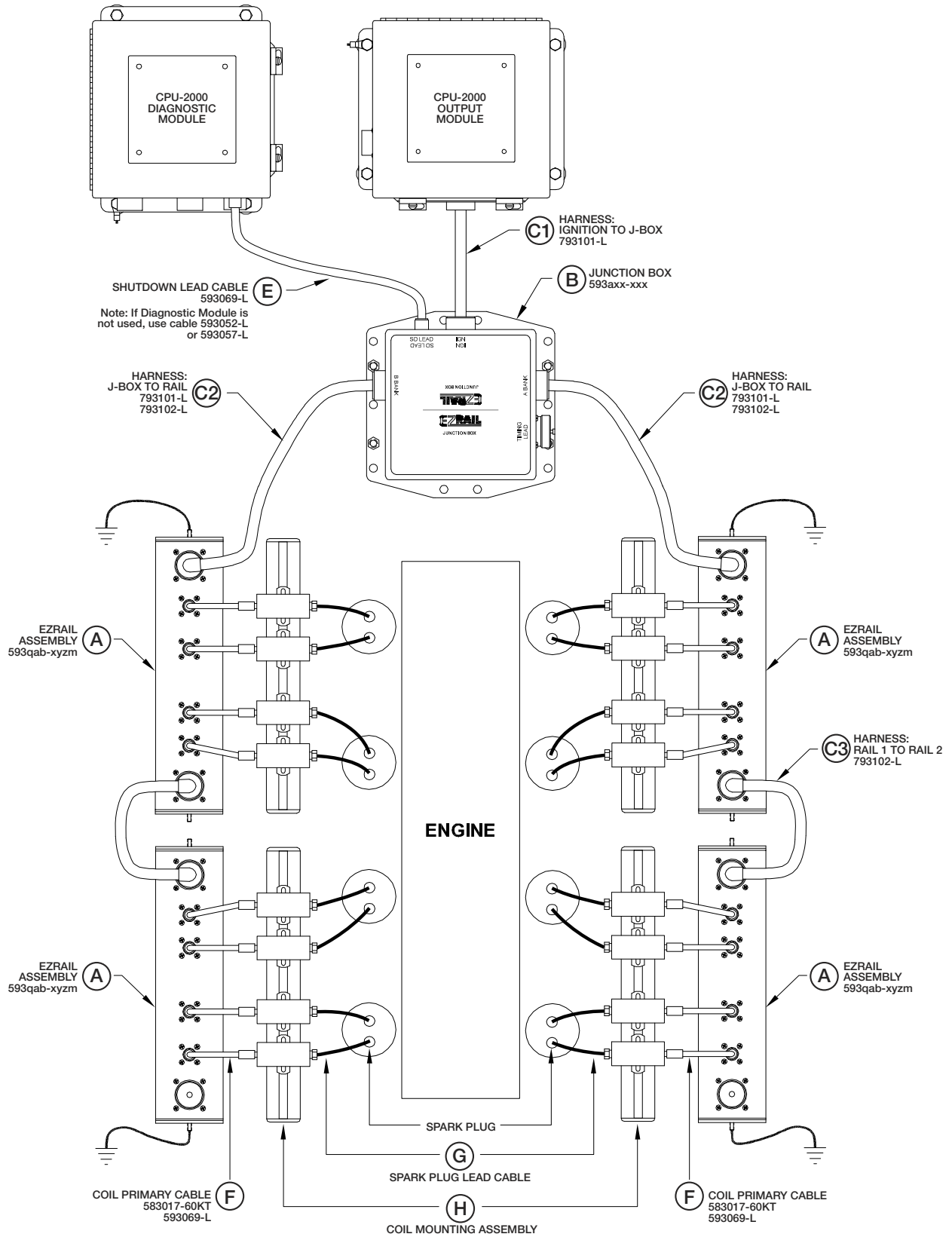

INSTALLATION INSTRUCTIONS

FIGURE 2 – DIMENSIONS: J-BOX

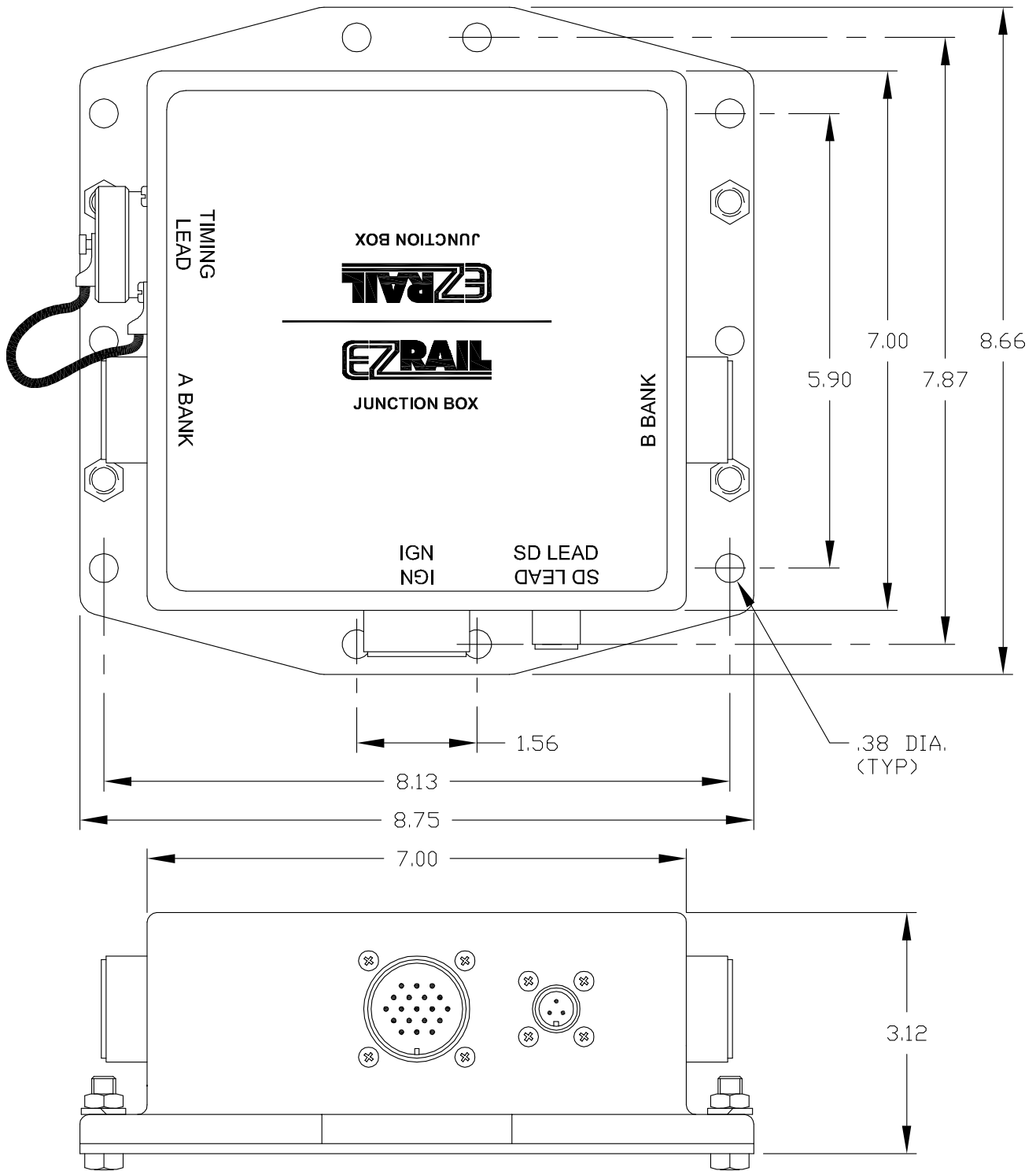
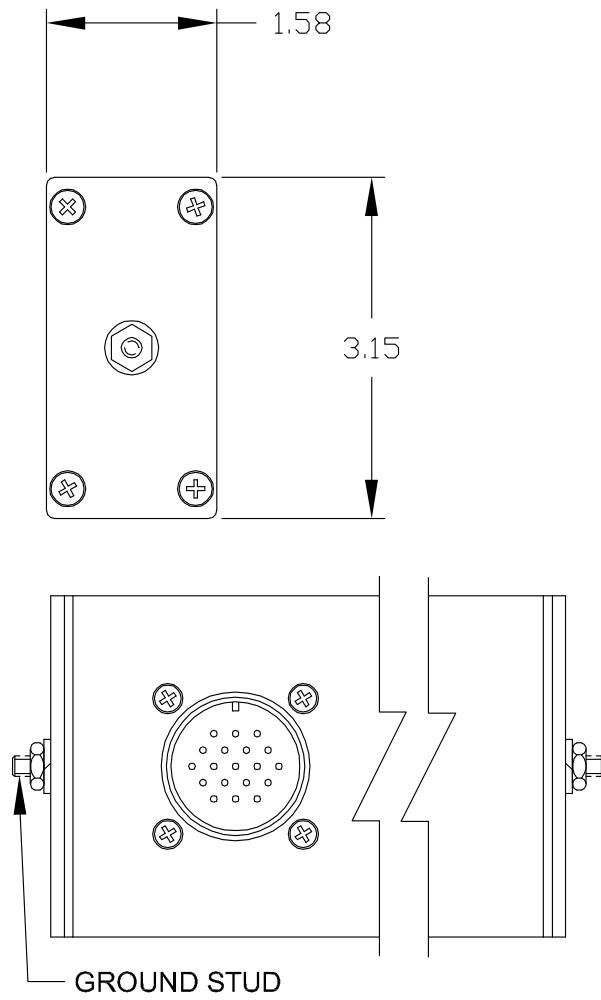

FIGURE 3 – DIMENSIONS: EZRAIL



INSTALLATION INSTRUCTIONS

NUMBER OF MOUNTING KITS PER RAIL

Eng. Cylinders	2	3	4	5	6	8	10	12
1 coil per cyl.	2	2	3	3	4	5	6	6
2 coils per cyl.	3	4	5	6				

LAYOUT WITH ONE COIL PER CYLINDER

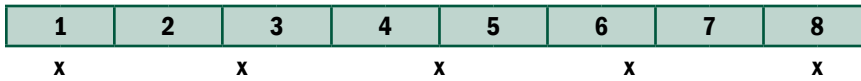
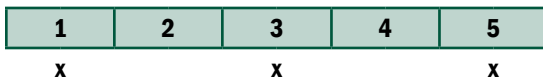
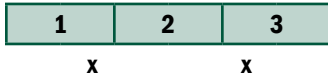

LAYOUT WITH TWO COILS PER CYLINDER

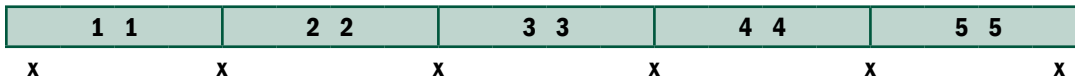
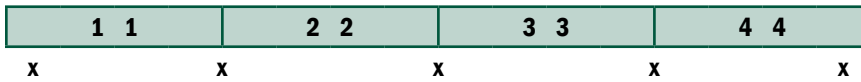
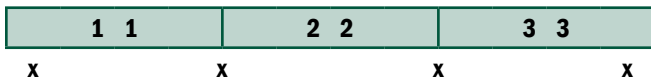
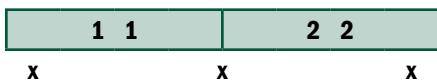

x = Mounting bracket between Primary Wiring Rail and Coil Mounting Rail